

**RONDO®**

**DUO®**  
Exposed Grid Ceiling System

DUO® installation guide

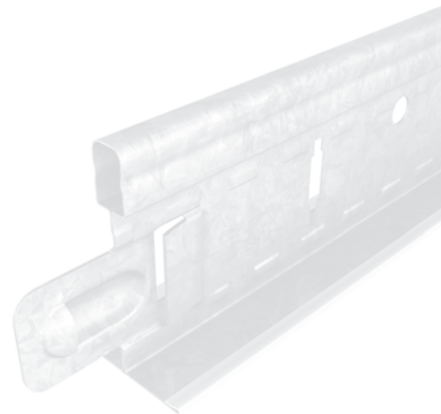

# RONDO DUO®

## EXPOSED GRID CEILING SYSTEM

### GENERAL INFORMATION

This brochure provides details of the Rondo DUO® Exposed Grid Ceiling System, which allows for integration with other Rondo suspended ceiling systems in the same plane. Below are just some of the features and benefits of choosing to use the Rondo DUO® grid system, and some of the products available to help meet your construction needs.

Note that this brochure is intended to be used as a guide only; full details should be obtained via the Rondo website. Rondo recommends installation by a qualified tradesperson and that you ensure you are referring to the latest version of this guide by comparing it to the one on our website.

### FEATURES & BENEFITS

FEATURE	BENEFIT
<b>Engineer-designed locking tabs on each cross tee</b>	Cross tees can be easily removed from an installed ceiling without damage and then reinstalled at another location. This is convenient when relocating light or air conditioning features. Locking tabs on each cross tee are manufactured from a high tensile steel to provide a strong and positive connection. The cross tee locking tab has been engineered to ensure that it will stay in place in the main tee whilst the opposite cross tee is being installed.
<b>Strong and exclusively designed “zipper” packaging for all standard main and cross tees</b>	Enables ease of opening and reduces the potential for damage. Packaging has also been designed to ensure that it will not break open while it is being transported and allows the carton to maintain its integrity for carrying once opened.
<b>Range of snap-on and hooked suspension clips as well as 50mm spaced holes for the tie wire on the main tee</b>	The Rondo DUO® main tee can be suspended anywhere along its length with a choice of suspension clips or tie wire.
<b>All components are produced with protective coatings</b>	Rondo is able to offer a performance guarantee for a minimum of 15 years for most environments.
<b>Code Compliance</b>	All components of the Rondo DUO® Exposed Grid Ceiling System have been designed and tested by Rondo engineers to meet the requirements of suspended ceiling and seismic design codes in both Australia and New Zealand.
<b>Technical Expertise</b>	For detailed technical information, visit <a href="http://www.rondo.com.au">www.rondo.com.au</a> to view the Rondo Professional Design Manual, or download the Rondo App. For all other advice, contact your local Rondo Technical Sales Representative.

### VARIOUS RONDO DUO® COMPONENTS



DUO 1      DUO 2      DUO H

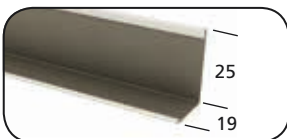

DUO 5

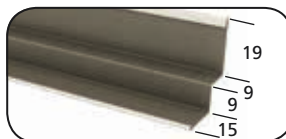

DUO 6

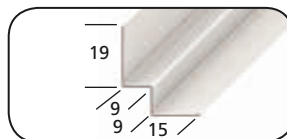

DUO 7

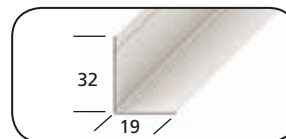

DUO 8



703



704



705



706



707



708



709



716



717

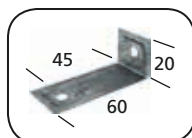

247

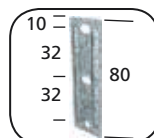

274



534



547



700

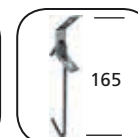

719



121

# RONDO DUO®

## TYPICAL APPLICATION DETAILS

1. Select your preferred grid layout to suit either 1200 x 600 or 600 x 600 ceiling panels as shown in Table 1, selecting the relevant cross tee based on the weight of the ceiling tile.
2. Set the grid out from the middle of the room to maintain equal cut panels to opposite walls.
3. Mark the ceiling height on the walls and fix the perimeter trim with suitable fasteners at max. 600mm centres, ensuring the fixing is made into the studs. Mitre the corner intersections and use joiners to connect angles as per Figure 1.
4. Fix the Main Tee suspension brackets as per Figures 2 & 6. Ensure the suspension brackets are installed at no more than 1200mm centres and spaced 1200mm on either side. Ensure the hanger points are set out so that hangers adjacent to the perimeter walls are no more than 300mm from the wall unless otherwise specified.
5. Assemble the Main Tee suspension clip to the suspension rods that have been pre-cut to length to suit your suspension drop. Ensure the suspension is vertical.
6. Ensure the pre-punched slots on the Main Tee line up, and fit the Main Tee to the clips, as per Figure 4. The Main Tees should now be spaced 1200mm apart and suspended 1200mm between hangers. Stagger joints between adjacent Main Tees.
7. Ensure the integrated self locking joiners on Main Tees are properly locked together. Where Main Tees abut the wall trim, secure with the relevant stabiliser clip as per Figure 3.
8. Fix Cross Tees into position through the slots in the Main Tee with a gentle push. The opposing cross tees positively lock together as per Figure 5. The slots in the Main Tee are spaced 100mm apart to ensure the correct space is maintained between the Cross Tees (600mm apart for a 1200 x 600 panel). Cross Tees abutting the wall trim should be secured with the relevant clip, as per Figure 3, at not more than 1800mm centres unless otherwise specified.
9. Finally, align and level the grid by adjusting the suspension clips up or down using a string line or laser as a guide.

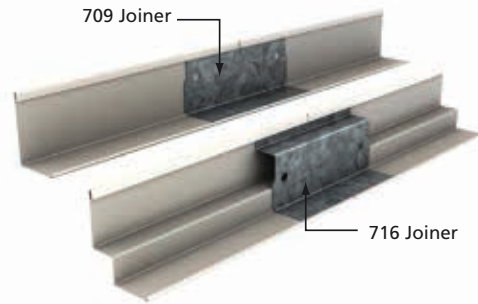

FIGURE 1: WALL ANGLE JOINERS

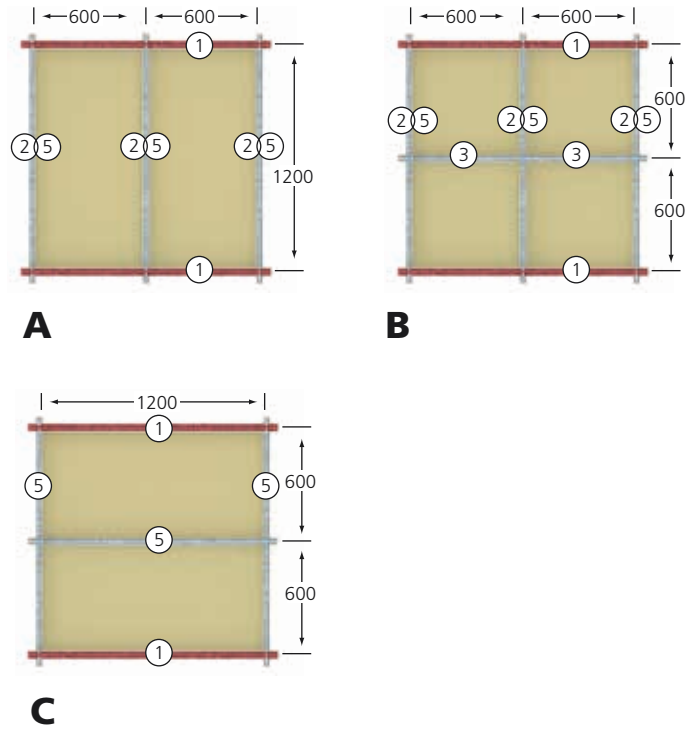

TABLE 1: TEE SPACING/MAX. ALLOWABLE LOADS

SYSTEM		FACE SIZE mm	SPACING OF M/TS mm	SPACING OF X/TS mm	ALLOWABLE LOAD kg/m <sup>2</sup> kg	MAX. WEIGHT OF LIGHT FITTINGS kg
<b>A</b>	DUO 1-H	24	1200	600	14.2	10
	DUO 1-2	24	1200	600	12.4	10
<b>B</b>	DUO 1-H	24	1200	600	14.2	10
	DUO 1-2	24	1200	600	12.4	10
<b>C</b>	DUO 1-H	24	1200	600	8.4	6

MAIN TEE	REF	PART NO	LENGTH
	①	DUO 1	3600

CROSS TEE	REF	PART NO	LENGTH
	②	DUO 2	1200
	③	DUO 2	600
	④	DUO H	1200

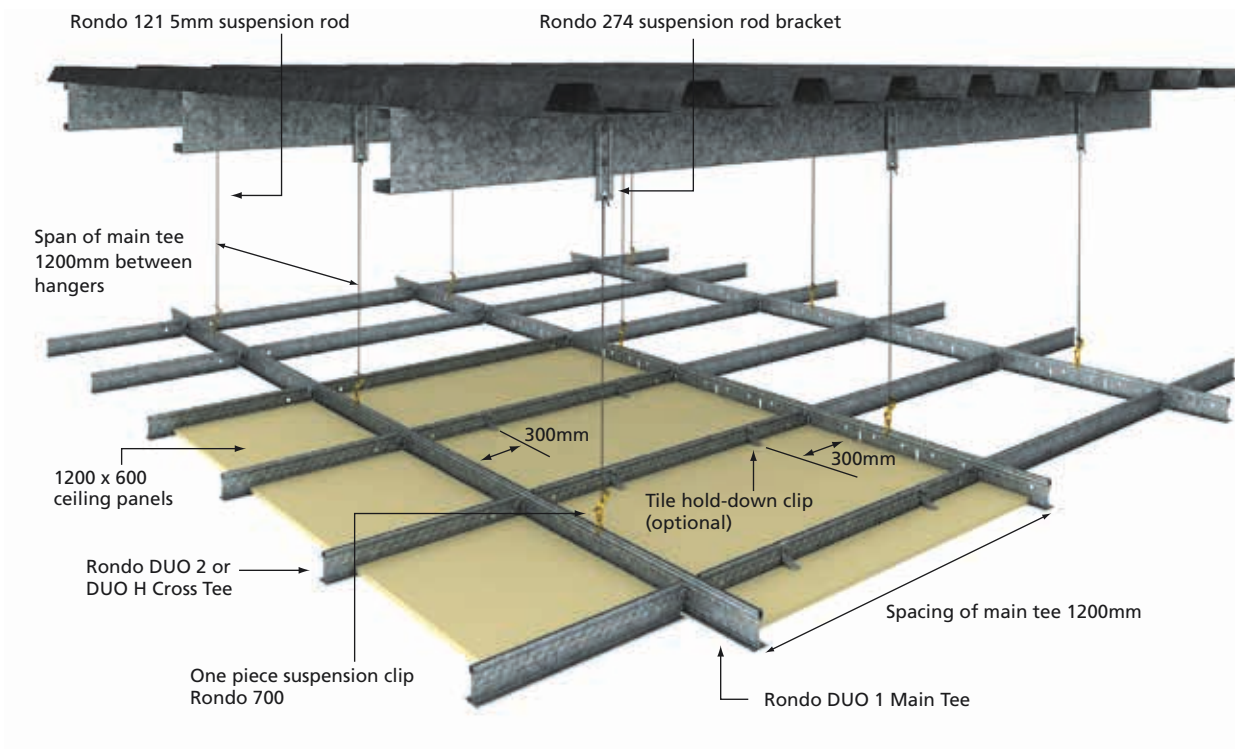

FIGURE 2: TWO-WAY EXPOSED CEILING SYSTEM DETAIL

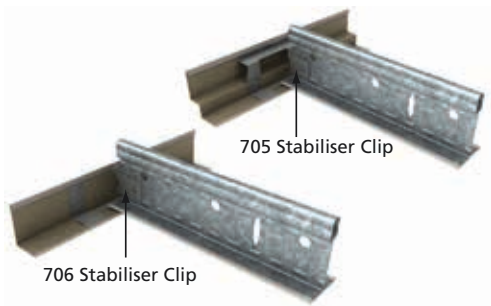

FIGURE 3: STABILISER CLIPS



FIGURE 4: INSTALLING THE RONDO 700 SUSPENSION CLIP

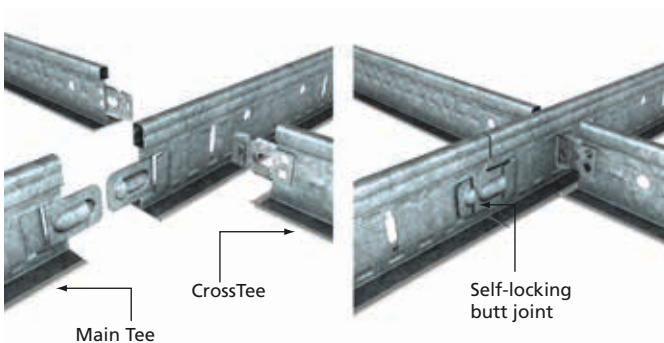

FIGURE 5: MAIN AND CROSS TEE JOINTING CROSS

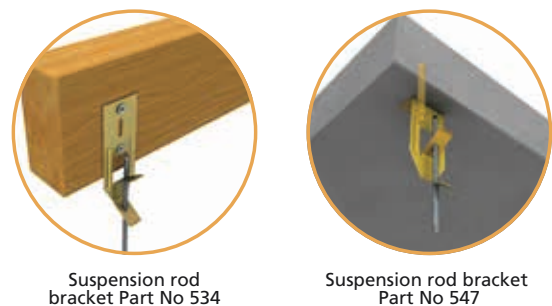

FIGURE 6: ALTERNATIVE SUSPENSION BRACKETS

The installation of troffer type light fittings can be accommodated by installing additional cross tees, but ensuring the weight of the light fitting is borne by the main tees only as Figure 7.

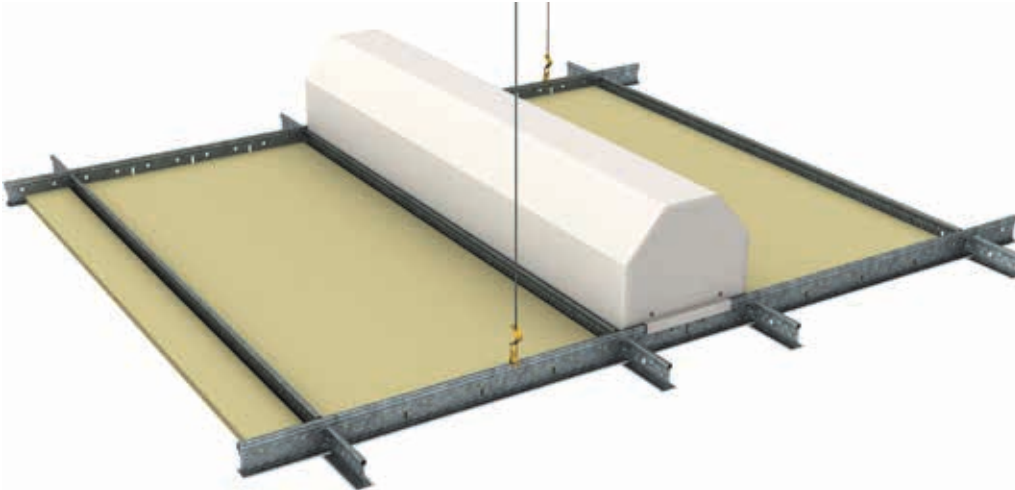

FIGURE 7: LIGHT FITTING DETAIL

NOTE: To ensure the weight of the fitting does not compromise the integrity of the grid additional hangers should be installed adjacent to the fitting if none already exist. See Table 1 for maximum weight of light fittings.

#### BULKHEADS

Changes in ceiling levels can be accommodated by the introduction of vertical bulkheads which can be constructed using plasterboard or ceiling panels as shown in Figures 8 & 9. More detailed information on bulkhead construction, or other DUO® applications such as One Way Exposed ceilings, sloping DUO® ceilings, linear diffusers, and securing partition head tracks to grid, is available in the Rondo Professional Design Manual on the Rondo website, [www.rondo.com.au](http://www.rondo.com.au).

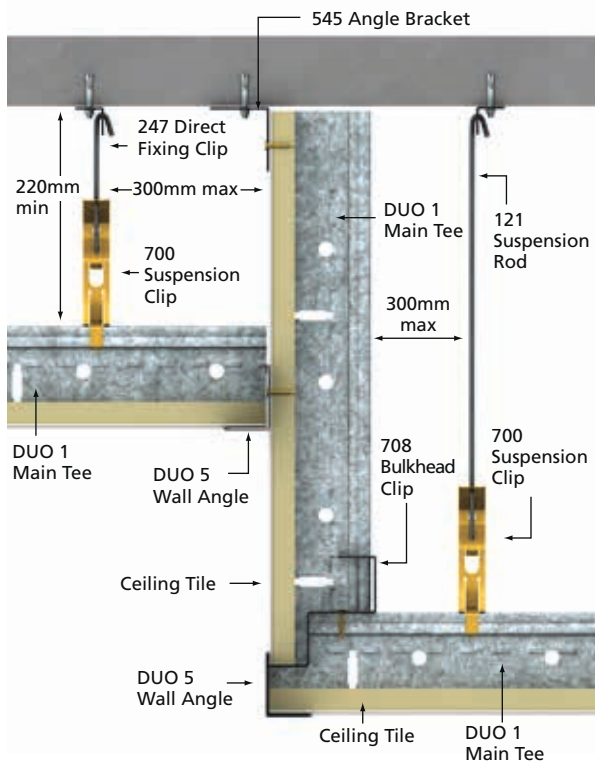

FIGURE 8: SQUARELINE BULKHEAD DETAIL (VERTICAL EXPOSED GRID)

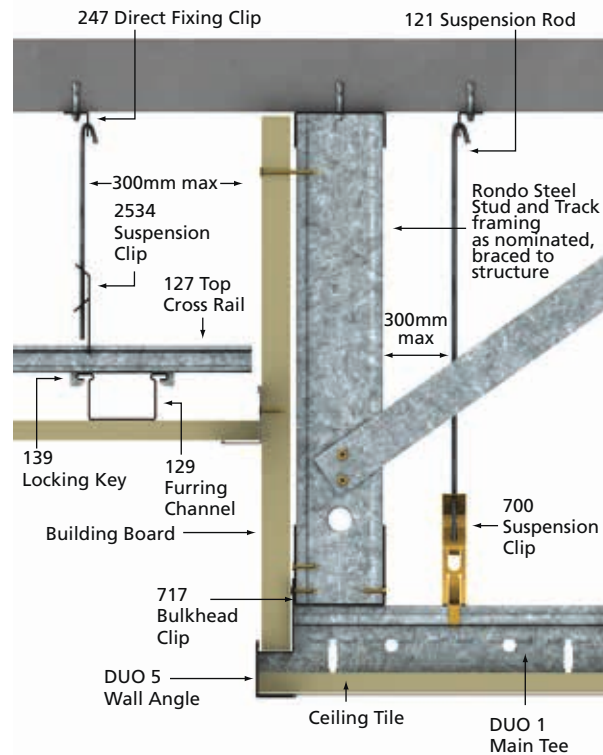

FIGURE 9: SQUARELINE BULKHEAD DETAIL (VERTICAL KEY-LOCK®/STEEL STUD SYSTEM)

NOTE: For all further information, speak to a Rondo Technical Sales Representative or for full installation details and warranty conditions, please visit our website at [www.rondo.com.au](http://www.rondo.com.au), download the Rondo App or speak to your local Authorised Rondo Distributor.

# RONDO OFFICES

## AUSTRALIA

### RONDO BUILDING SERVICES PTY LTD

CUSTOMER SERVICE HOTLINE: 1300-36-RONDO (1300-36-7663)

### NEW SOUTH WALES

57-87 Lockwood Road Erskine Park NSW 2759

(PO Box 324 St Marys NSW 1790)

phone: 61-2-9912 7300

fax: 61-2-9912 7310

email: nsw@rondo.com.au

### VICTORIA

12-14 Dunlop Road Mulgrave VIC 3170

(Private Bag 23 Mulgrave VIC 3170)

phone: 61-3-8561 2222

fax: 61-3-8561 2266

email: vic@rondo.com.au

### QUEENSLAND

13 Binary Street Yatala QLD 4207

(PO Box 6006 Yatala QLD 4207)

phone: 61-7-3442 6400

fax: 61-7-3442 6427

email: qld@rondo.com.au

### SOUTH AUSTRALIA

39 George Street Green Fields SA 5107

phone: 61-8-8256 5900

fax: 61-8-8256 5922

email: sa@rondo.com.au

### WESTERN AUSTRALIA

5 Hazelhurst Street Kewdale WA 6105

(PO Box 168 Cloverdale WA 6985)

phone: 61-8-9251 9400

fax: 61-8-9251 9414

email: wa@rondo.com.au

### HEAD OFFICE

57-87 Lockwood Road Erskine Park NSW 2759

(PO Box 324 St Marys NSW 1790)

phone: 61-2-9912 7303

fax: 61-2-9912 7313

email: rondo@rondo.com.au

### EXPORT

phone: 61-438-427-479

fax: 61-7-3287-1881

email: export@rondo.com.au

## NEW ZEALAND

### RONDO BUILDING SERVICES PTY LTD

117A Captain Springs Road Onehunga Auckland 1061 New Zealand

(PO Box 12464 Penrose Auckland 1642 New Zealand)

phone: 64-9-636 5110

fax: 64-9-636 5111

email: newzealand@rondo.com.au

FREE CALL: 0800-0800-RONDO (0800-0800-76)

## MALAYSIA

### RONDO METAL PRODUCTS SDN BHD

Lot 606, Off Jalan SS13/1K

47500 Subang Jaya Selangor

phone: 60-3-5636 0710

fax: 60-3-5636 0711

## INDIA

### RONDO METAL SYSTEMS PVT LTD

Plot No. J-21, MIDC Talaja, Tal. Panvel

Dist. Raigad - 410-208 Mumbai India

phone: 91-22-2740 2831

# RONDO®

[www.rondo.com.au](http://www.rondo.com.au)

This brochure is printed on 55% recycled paper and 45% pulp from responsible forestry, FSC® Certified. RONDO® and DUO® are registered trademarks of Rondo Building Services Pty Ltd. ABN 69 000 289 207.

First Printed MAY 2009. Revised OCT 2013.

